

A NEW SIMULATION-OPTIMIZATION APPROACH FOR THE CIRCULATION FACILITIES DESIGN AT URBAN RAIL TRANSIT STATION

Afaq Khattak¹, Yangsheng Jiang², Juanxiu Zhu³, Lu Hu⁴

^{1,2,3,4}Traffic Engineering Department, School of Transportation and Logistics, Southwest Jiaotong University, National United Engineering Laboratory of Integrated and Intelligent Transportation, Chengdu, Sichuan China

¹e-mail: af.transpo@gmail.com

²e-mail: jiangyangsheng@swjtu.cn

³e-mail: zhjuanxiu@163.com

⁴e-mail: hulu361@126.com

Abstract: Width design of the urban rail transit stations circulation facilities is a vital issue. The existing width design approach failed in fully considering the essential factors such as fluctuation in passengers' arrival process, fluctuation and state-dependence in passengers walking speed and the blocking when passengers' demand exceeds the capacity of facilities. For this purpose, a PH-based simulation-optimization approach is proposed that fully considers the fluctuation, the state-dependence, Level of Service (LOS) and blocking effect. This novel approach provides automatic reconfiguration of the widths of circulation facilities by a concurrent implementation of a PH-based Discrete-Event Simulation (DES) model and the Genetic Algorithm (GA). The proposed PH-based simulation- optimization approach and the existing design approaches based on the exponential and deterministic models are applied to design the widths of circulation facilities. The results reveal that the circulation facilities designed by the proposed approach have larger widths. Similarly, increase in the SCV of arrival interval results in increasing the widths designed by the proposed approach increase while the widths of the other two approaches stay the same. The width designed of the proposed approach increase at faster rate than that of the other two approach when the passengers' arrival rate increases.

Key words: Urban Rail Transit Station, Circulation Facilities, PH-based Discrete-Event Simulation, Genetic Algorithm, PH-based Simulation-Optimization.

1. Introduction

The urban rail transits are playing a significant role in the urban transport, especially in metropolises. The urban rail transit stations are the operational systems consisting of a framework of infrastructures, service facilities, and personnel; they are the points of connection between arrivals and departures of passengers. In recent years, investment and improvement in the urban rail transits encouraged the people to switch from driving to transits.

The performance of the urban rail transit station service facilities naturally became a great concern to both passengers and operators. The better performance of these service facilities is the reflection of enhanced design while the inadequate design often leads to high-level congestion, the longer travel time of passengers between the service

facilities, inefficient space utilization, resource wastage and increase in the waiting time of passengers which in turn implies that there is a direct correlation between design and performance. The width (W) of the circulation facilities (corridors and stairs) is a most significant factor and its design is a vital issue. It is obtained by using the passengers' arrival rate divided by the service rate (flow rate) per unit width under a given Level of Service (LOS) in the Transit Capacity and Quality of Service Manual (TCQSM) (Kittelson et al., 2003) but they have a several shortcomings, such as;

- The design procedure neglect fluctuation in passengers' arrival process.
- The fluctuation as well state-dependence walking speed of passengers is ignored.

- Several service facilities of urban rail transit stations are designed separately and the correlation between them is fully neglected.
- The analysis and design procedure neglect blocking phenomenon in different facilities when the passengers' demand exceeds the serviceability of the facilities.

Due to all these shortcomings, the circulation facilities designed by the TCQSM always show poor performance and face blockage even during the off-peak hours. The heavy congestion and blocking can cause serious accidents if not controlled. Thus, there is an urgent need for a new design approach for circulation facilities that overcome the shortcomings.

Therefore, the study reported in this research details the Discrete-Event Simulation (DES) as well as the *simulation-optimization* approach for the analysis and optimal design of urban rail transit station service facilities, considering both the fluctuation in passengers' arrival process and the service times of the circulation facilities. The Phase-Type (PH) distribution considers the randomness factor and therefore it is used to fit the passengers' arrival and service processes in the DES model. Moreover, the PH-based *simulation-optimization* approach, integrating the PH-based DES models of the service facilities and the optimization algorithm based on Genetic Algorithm (GA) is used to design the facilities and eliminates the need to solve explicit analytical expressions over a large time span, as in the case of mathematical optimization.

The assessment of LOS in circulation facilities uses the area occupied per passenger (m^2/ped) as the basis for classification (See Exhibit 7-3 and 7-7 in Reference Kittelson et al. 2003). It reflects proximity to other passengers and is therefore considered as an indicator of the passenger level of comfort and freedom to maneuver without conflict. In this paper, both the corridors and stairs are designed under the LOS 'B'. According to TCQSM, the minimum LOS 'B' values for corridors and stairs are $2.3 m^2/ped$ and $1.4 m^2/ped$ respectively.

Moreover, in this research, the Genetic Algorithm (GA) and PH-based BES are implemented in the *MATLAB*[®] Scientific Computing Environment and *SimEvents*[®] simulation software (a Discrete-Event Simulator in the *MATLAB*[®]/*Simulink*[®] family), respectively.

- The *MATLAB*[®] offers a computational environment for optimizing hybrid discrete-event and time-based models, that allows for a great flexibility in scripting and modifying the optimization objective and constraint functions. It also making easier to tie together the parallel DES and optimization script without the pain of the context transferring into the multiple softwares.
- Just like other simulation tool, such as Arena , Extend, Witness) and Any Logic., the *SimEvents*[®] (Banks, 2010) allows the representation of complex Discrete-Event Systems by a network of queues, servers, gates and switches based on the events. Its integration with the *MATLAB*[®] simplifies the modeling process of the hybrid dynamical systems, which include discrete-time, continuous time and discrete-event systems. The *SimEvents*[®] contains libraries and block sets that model the basic components of DES. By inter-connecting these building blocks, one can easily model a DES of transportation systems, communication networks, and manufacturing systems, etc.

2. Literature Review

Several researches has been carried out to devise the new width design approach for the circulation facilities in urban rail transit stations as well as other buildings such as residential, hospitals and universities. Due to the inherent characteristics of circulation facilities, such as the relationship between the facilities and passengers (servers and customers), the fluctuation and state-dependence in the passengers' flow, many researches modeled the circulation facilities as various queuing systems. Based on this, both the analytical and simulation models are developed. The first approach uses mathematical techniques often called queuing analytical models to estimate the performance measures by using mathematical equation systems. The second approach is a computer simulation of the facilities. In the simulation environment, all quantities can be readily observed and the parameters can be changed to examine their influence on the system.. Generalized M/G/C/C state-dependent analytical queueing models pedestrian traffic flow established by Yuhaskiet al. (1989), Smith et al. (1991), Cheah et al. (1994), Cheah and Smith (1994) and Chen et al. (2012). Similarly, Jian and MacGregor Smith (1997)

developed a queuing model for the vehicular traffic flow. Vandaele et al. (2000) developed a finite capacity queuing networks to consider traffic flow studies on roads. Mitchell and MacGregor Smith (2001) extended their work to analyze and design the series, splitting and merging topologies of pedestrian network by using an analytical approximation methodology. Cruz et al. (2005) developed a state-dependent M/G/C/C queueing networks to determine the optimal capacity and number of servers. Jiang et al. (2010) modelled the urban rail transit station corridor facility as a M/G/1 queuing system with the passenger arrival process based on exponential distribution and a service time based on general random distribution. Bedell and Smith (2012) examined the combination of multi-server and state-dependent M/G/C/K, M/G/C/C queues in transportation and material handling systems. Xu et al. 2014 analyzed the Urban rail transit station Capacity (SSC) as M/G/C/C state-dependent queuing network. A new concept according to the gathering and scattering process was defined.

With the advancement of computer technologies, the simulation approach has been emerged and many researchers focused on simulation approach for the analysis and design purposes. The G/M/1 queuing network simulation model by Lovas (1994), the M/G(n)/C/C state dependent network simulation model by Cruz et al. (2005) and Khalid et al. (2013). Ying et al. (2014) developed a queuing simulation and optimization model for number of ticket windows at urban rail transit station. A DES model is also developed by (Jiang and Lin, 2013) for the evaluation and optimization of the Ticket Vending Machines (TVM) at urban rail transit station using log-normal distribution and gamma distribution for arrival and service processes, respectively. In these researches, queuing systems are translated into Discrete-Event Simulation (DES) models. Based on the DES models, both evaluation and optimization are carried out. However, circulation facilities description still needs to be improved in the above researches.

Besides DES, another simulation category is also well known, that is the microscopic simulations. Microscopic simulation models are elaborate as they depict individual characteristics and behaviors of the pedestrians (Teknomo et al., 2006, Kaakai et al., 2007) as well as transportation system (Jacyna et al.,

2014). However, they require extensive calibration work and larger computation time at the same time. On the contrary, DES does not require the specific physical environment and passenger entity, making it more efficient and easier to calibrate than microscopic simulation models. Therefore, DES is taken as an efficient and accurate simulation method with a wide range of application (Hassannayebi et al., 2014). Another advantage of the DES is that *simulation-optimization* can be carried out conveniently based on DES models due to its universality and efficiency.

From the review of advanced stochastic processes study, we found that the Phase-Type (PH) distribution has substituted the exponential distribution in several fields including; healthcare, queuing systems, manufacturing processes and communication systems. The reason to use PH distribution for fitting the arrival interval and service time in queuing system is its own apt analyticity, universality, and computability Jiang et al. (2013). Theoretically, it can be fit to any positive random number infinitely which has resulted in the emergence of ample PH-based queuing models including PH/PH/1 by Krishnamoorthy et al. (2008) and PH/PH/1/C by Alfa and Zhao (2000). In the transportation domain, Hu et al. 2013 for the first time applied the PH distribution to fit the passengers' flow arrival interval distribution at urban rail transit station which has revealed a good data fitting effect. It has opened the ways for using PH distribution in the field of traffic and transportation. Reijtsbergen et al. (2015) proposed a methodology of constructing stochastic performance model for public transportation network using PH distribution.

Hu et al. (2015) presented an analytical PH/PH/C/C state-dependent queuing model for the analysis and design of urban rail transit station corridors. The PH/PH(n)/C/C state dependent queuing model take the state-dependence in service time into consideration. State dependence describes the phenomenon in circulation facilities the number of passengers (referred as system state n) affect the walking speed, which eventually affects the service time. However, it is very difficult to solve the PH/PH(n)/C/C state dependent analytical model even for a single facility. The complexity of solving the PH/PH(n)/C/C state dependent network model will be much larger due to the matrix operations. In

addition, the blocking probability is not controlled when designing the width for the single corridor facility in Hu et al. (2015).

Recently, *simulation-optimization* has become a popular and efficient tool in many domains (Banks, 2010; Hagendorf et al., 2013; Jiang et al., 2013 and Jiang et al., 2015). It involves the optimization of model inputs by using simulation for the computation of parameters (Figueira et al., 2014). Therefore, it is not necessary to provide an explicit analytical expression of the objective or constraint functions for optimization as in the case of analytical approach (Swisher et al., 2000; Fu, 2002, Cassandras et al., 2009; Hagendorf et al., 2013). This is especially useful in some practical situations where the explicit analytical formulas are too complex to be deduced.

To find the optimal widths for the circulation facilities by a PH-based *simulation-optimization* approach, we need to implement an optimization approach integrated with PH-based DES model. The Genetic Algorithm (GA) is chosen in this paper. There are several reasons for applying a GA rather than any other traditional optimization methods. One of the important reasons is its implicit parallelism (Swisher et al., 2000; Hubscher-Younger et al., 2012; Messac, 2015 and Lewczuk, 2015). The GA searches parallel from a population of points. As GA has multiple offspring, it can explore the solution in different directions at a time giving it greater chance to find the optimal solution, while other traditional methods search from a single point and may trap in local optimal solution.

Based on the above analysis, we aim to propose a new PH-based *simulation-optimization* approach for the width design of circulation facilities. The contribution of this paper falls into two aspects. First, we establish a PH-based DES model to describe the circulation facilities (include stairs and corridors) in the urban rail transit station. The PH-based DES model captures the general fluctuation in passengers' arrival and service facilities. It also takes the state-dependence in service time into consideration. Therefore, it can be used to accurately evaluate the performance of the circulation facilities. Besides, it also serves as an important tool to validate the PH/PH(n)/C/C analytical model developed in Hu et al. (2015). Second, we develop a PH-based *simulation-optimization* approach by implementing the PH-based DES model and the GA

to work concurrently. The PH-based *simulation-optimization* approach determines the optimal widths of circulation facilities by considering the requirements on both LOS and blocking probability. Therefore, the circulation facilities designed by it enjoy higher service quality and less congestion. The proposed PH-based *simulation-optimization* approach can support decision making in circulation facilities design

3. Notations

Notation	Description
α	Initial probability vector
D	Transient Generator Matrix
L	Length of the walkway (m)
W	Effective width of the walkway (m)
C	Capacity of the walkway
n	Number of passengers (system state)
λ	Passenger arrival rate (ped/h)
c_a^2	Squared Coefficient of variation of arrival rate
q	Peak-hour volume
ϵ	Peak-hour factor
h	Mean headway between the trains (sec)
c_h^2	Squared coefficient of variation of headway
μ_n	State-dependent service rate
T_n	State-dependent service time of walkway
V_n	State-dependent walkway speed of passengers
$c_{s,n}^2$	State-dependent squared coefficient of variation of walkway service rate
P_c	Blocking probability
ES	Mean area occupied per passenger
f	Degree of Erlang distribution
U	Uniformly distributed random number

4. Definition of PH Distribution

Before going into the details of PH-Based DES model, the PH distribution is discussed first. The PH distribution is a probability distribution that represents the time to absorption in a Continuous-Time Markov Chain (CTMC) with one absorbing

state and all the other transient states (Neuts, 1981). PH distributions are commonly represented by the pair (α, \mathbf{D}) . Here, α is an initial probability vector and \mathbf{D} is a transient generator matrix as follows

$$\alpha = (\alpha_1, \dots, \alpha_n), \quad \mathbf{D} = \begin{pmatrix} d_{11} & \dots & d_{1n} \\ \vdots & \ddots & \vdots \\ d_{n1} & \dots & d_{nn} \end{pmatrix}.$$

The probability density function (PDF) and cumulative distribution function (CDF) of PH distribution are given by Equation (1) and (2)

$$f(x) = \alpha e^{\mathbf{D}x} d \tag{1}$$

$$F(x) = 1 - \alpha e^{\mathbf{D}x} \mathbf{1} \tag{2}$$

where: $d = \mathbf{D}\mathbf{1}$ and $\mathbf{1}$ is a column vector of one's of the appropriate size .

There are four conditions given for fitting PH distribution (Sadre and Haverkort, 2011; Sadre, 2007) based on the mean value and the SCV:

- 1) If the SCV c^2 for both the arrival and service processes is less than 1, a hypo-exponential distribution is used to fit the arrival and service processes with the number of phases given by $m = \frac{1}{c^2}$, the initial probability vector is $\alpha = (1, 0, \dots, 0)$ and the matrix \mathbf{D} is expressed by:

$$\mathbf{D} = \begin{pmatrix} -d_0 & d_0 & & & & \\ & -d_1 & d_1 & & & \\ & & \dots & \dots & & \\ & & & -d_{m-2} & d_{m-2} & \\ & & & & -d_{m-1} & \end{pmatrix},$$

where:

$$d_j = \frac{m}{E[X]} \text{ for } 0 \leq j < m-2 ;$$

$$d_{m-1} = \frac{2m \left[1 + \sqrt{\frac{1}{2} m (m c^2 - 1)} \right]}{E[X] (m + 2 - m^2 c^2)} ;$$

$$d_{m-2} = \frac{m \lambda_{m-1}}{2 \lambda_{m-1} E[X] - m} .$$

- 2) If the SCV c^2 is greater than 1 for both the arrival and service process, a hyper-exponential distribution is used for fitting with the number of phases $m = 2$, the initial probability vector is $\alpha = (g, 1-g)$ and the matrix \mathbf{D} is given by :

$$\mathbf{D} = \begin{pmatrix} \frac{-2g}{E[X]} & 0 \\ 0 & \frac{-2(1-g)}{E[X]} \end{pmatrix} \text{ and } g = \frac{1}{2} + \frac{1}{2} \sqrt{\frac{c^2-1}{c^2+1}}$$

- 3) If c^2 is equal to 1, then the approximation corresponds to an Exponential distribution.
- 4) If c^2 is very small i.e., $c^2 \leq 1/30$ then the PH distribution with a large number of states is obtained and its approximation corresponds to an Erlang-30 distribution.

Jiang et al. (2013) and Hu et al. (2015) have achieved a good fitting effect for the passenger arrival interval from the train as well state-dependent service time of circulation facilities by using a PH distribution with any SCV. The four conditions show that we can determine the PH representation for the arrival interval and service time based on $\lambda_i, c_{i,a}^2, \mu_{i,n}$ and $c_{i,s,n}^2$. Note that $E[X]$ is the reverse of the arrival rate λ_i and the service rate $\mu_{i,n}$.

5. Circulation Facilities as a Queuing System

The necessary assumptions used in this paper are discussed first followed by describing the PH-based DES model of circulation facilities.

5.1. Assumptions

Few basic assumptions are presented before the modeling of circulation facilities.

- The circulation facilities including both corridors are stairs are rectangular in shape with Length (L) and Width (W). The Width W is the effective width of circulation facility and the total width is obtained by adding a buffer of 0.5m on each side to the effective width.
- The passengers are assumed to be uniformly distributed in the circulation facilities. This is quite rare from a practical point of view but an important assumption for queuing analysis which

is used in many relevant studies such as Yuhaski et al. (1989), Jiang et al. (2015) and Hu et al. (2015).

- Only the alighting passenger flow from the train is considered. The proposed approach can also deal with bi-directional or multi-directional passenger flow by changing some parameters as well using additional blocks of *SimEvents*[®] simulation software.

5.2. Modeling of Circulation Facilities

The circulation facility of urban rail transit station is a type of open queuing network. Passengers enter the stairs or corridors and leave the facilities after receiving services. The circulation facilities include stairs and corridors (see Figure 1a) and they are turned into a topology of the queuing network system (see Figure 1b). The circulation facilities (nodes of a queuing network) are designated by

$i = 1, 2, \dots, N$, where; N is the total number of circulation facilities.

The flow lines represent the passengers flow at different circulation facilities with the routing probabilities represented by R_{st} . Here ‘s’ is the preceding facility and ‘t’ is the successor facility. When the alighting passengers on the platform entering into a circulation facility, they occupy the spaces in the facility (squares) (See Figure 2). Each available space in the circulation facility acts as a server (service desk). The passengers spend some time (walking/travel time) in the circulation facility and then exit. The passengers and the circulation facility can be viewed as a queuing system with passengers as customers, the spaces in the circulation facility as servers and the process of walking in the circulation exit facility as a service process.

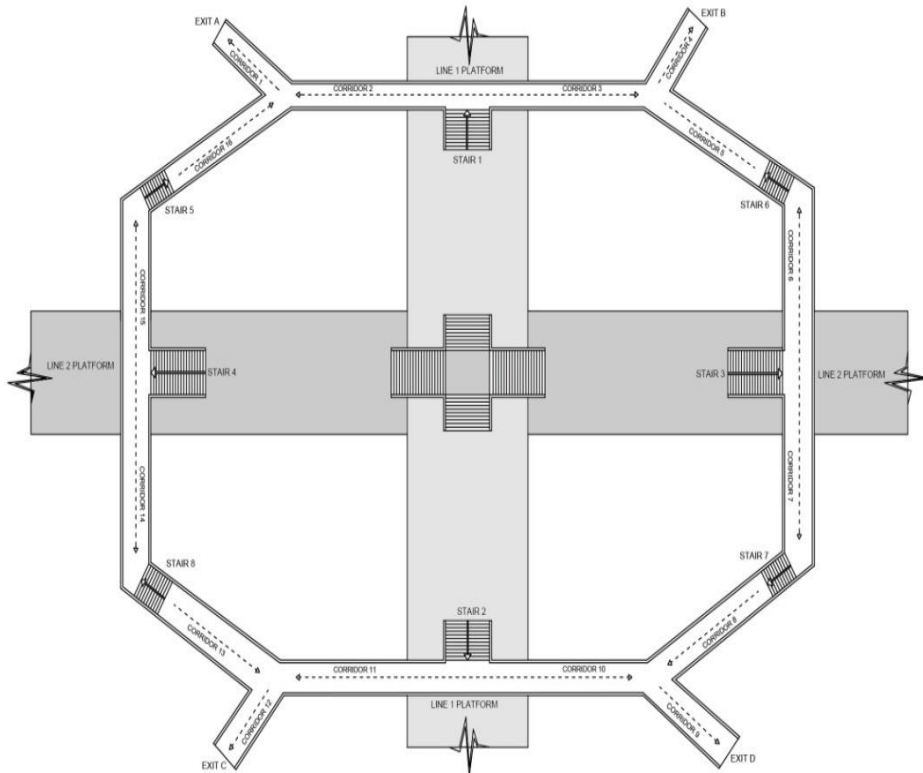

Fig. 1a. Queuing network representation of circulation facilities - Layout of the urban rail transit station circulation facilities

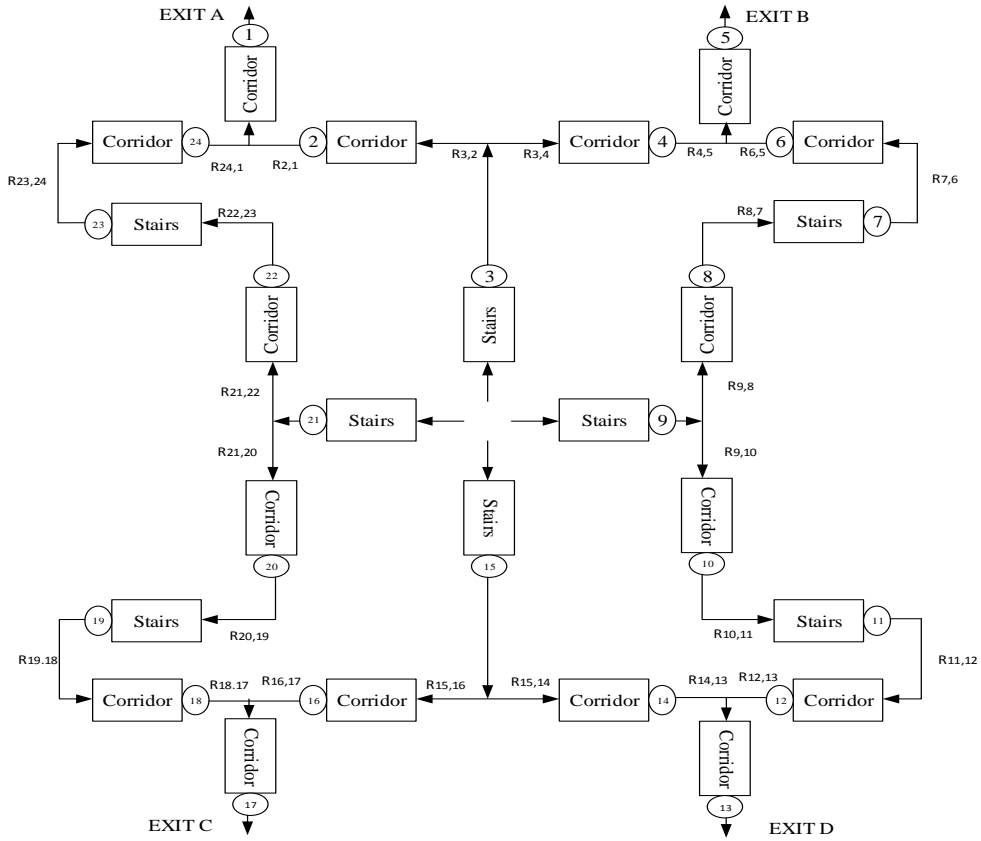

Fig. 1b. Queuing network representation of circulation facilities - Queuing network topology for circulation facilities

The number of passengers ‘ n ’ changes in the circulation facility dynamically over time. As the number of passengers in the circulation facility increases, the slower passengers block faster passengers. Thus, higher passenger densities reduce the individual passenger’s walking speed. The speed is reduced to 0 when the number of passengers n reaches the capacity of the circulation facility $C = 5LW$, which means the passenger flow in the circulation facility can be viewed as stopped when the density of passengers is a 5 ped/m² (Tregenza, 1976). The phenomenon of variation in walking speed with the increase or decrease in the number of passengers ‘ n ’ in the circulation facility is known as state-dependence. Hence, any circulation facility can be described as a state-dependent queuing

system with passenger arrival interval represented by the random variable A_i , state-dependent service time of the circulation facility $B_i(n)$, the number of servers (available positions) C_i , i.e., a $A_i/B_i(n)/C_i/C_i$ queuing system.

Since the value of C_i is generally very high in hundreds and even thousands. The queuing systems with a high value of C_i are difficult to simulate and cause serious problems in optimization such as low optimization efficiency. Therefore, it is necessary to simplify the $A_i/B_i(n)/C_i/C_i$ queuing system. We use the idea of transformation which is also used in relevant researches (Jiang et al., 2015; Hu et al., 2015). The transformation works as follows. A virtual line and a virtual server are set at the exit of the circulation facility, as shown in Figure 2.

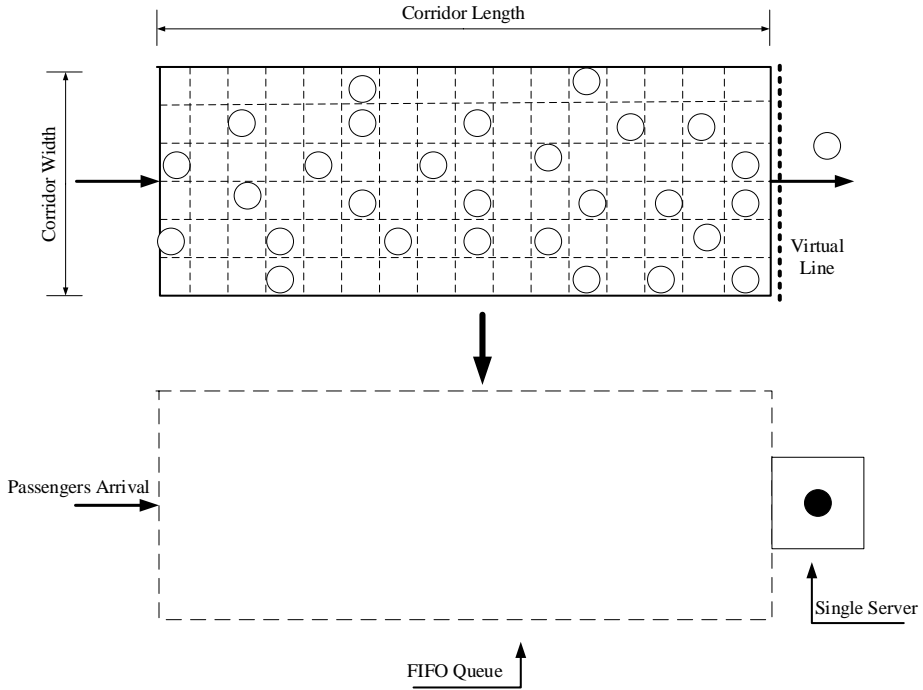

Fig. 2. Transformation of circulation facility to a single server queuing system

When two sequential passengers pass through the virtual line, the time interval T_n is recorded. If the time at which the previous passenger leaves the circulation facility is viewed as the time the next passenger begins to be served, then the time interval between these two sequential passengers passing through the virtual line is equal to the service time of the virtual server. In this way, the $A_i/B_i(n)/C_i/C_i$ queuing system with C_i parallel-serial servers can be transformed equivalently to an $A_i/B_i(n)/1/C_i$ queuing system with a single server. Note, the service time of the virtual server $B_i'(n) = B_i(n)/n$. How to calibrate the parameters for the PH arrival interval and service time will be discussed in the next subsection.

5.3. Passengers' Arrival Process

The passengers' arrival process to the i^{th} circulation facility of urban rail transit station is specified by passenger the arrival rate λ_i and squared coefficient of variation (SCV) of arrival interval $c_{i,a}^2$ (Jiang et

al., 2013). During the planning and design phase of urban rail transit station circulation facilities, the peak hour volume (q) and the peak-hour factor (ε) are usually given. So we can calculate λ_i and SCV ($c_{i,a}^2$) of the i^{th} circulation facility by:

$$\lambda_i = \frac{q}{3600\varepsilon} \tag{3}$$

$$c_{i,a}^2 = \frac{e^{6.819\varepsilon}(\varepsilon - 1)^2}{4\varepsilon - 1} \tag{4}$$

If the mean headway (h) between trains and the squared coefficient of variation of headway (c_h^2) is also given (for the existing urban rail transit station), then $c_{i,a}^2$ can also be calculated by:

$$c_{i,a}^2 = e^{0.503\varepsilon h^2} \left[\left(\frac{qh}{3600\varepsilon} \right) - 1 \right] \tag{5}$$

5.4. State-dependent Service Phase

According to TCQSM (Kittelson et al., 2003) and the traffic flow theory, the passengers flow rate (μ) is given by Equation (6):

$$\mu = kV \tag{6}$$

Here k is the density of passengers and V is the passengers' walking speed in the circulation facility. In the case of urban rail transit station circulation facilities, the passenger flow rate is the number of passengers passing through the circulation facility per unit time. The reciprocal of flow rate $1/\mu$ is referred as the time interval of the passengers leaving the circulation facility which is also the state-dependent service time T_n of the single virtual server in Figure 2. Therefore, the state-dependent service time of the i^{th} circulation facility can also be expressed as:

$$T_{i,n} = 1/\mu_{i,n} = L_i / nV_{i,n}, \quad i = 1, 2, \dots, N \tag{7}$$

The state-dependent service rate of the i^{th} circulation facility can be written as:

$$\mu_{i,n} = 1/T_{i,n} = nV_{i,n} / L_i, \quad i = 1, 2, \dots, N \tag{8}$$

Here L_i is the length and $V_{i,n}$ is the state-dependent walking speed of passengers passing through the i^{th} circulation facility. Yuhaski et al. (1989) developed an exponential model to describe the state-dependent walking speed in i^{th} circulation facility, shown by Equation (9):

$$V_{i,n} = V_i \exp \left[- \left(\frac{n-1}{\omega_i} \right)^{\gamma_i} \right], \quad i = 1, 2, \dots, N \tag{9}$$

where:

$$\gamma_i = \ln \left[\frac{\ln(v_{i,a} / v_{i,1})}{\ln(v_{i,a} / v_{i,1})} \right] / \ln \left(\frac{a_i - 1}{b_i - 1} \right),$$

$$\omega_i = (a_i - 1) \left[\ln \left(\frac{v_{i,1}}{v_{i,a}} \right) \right]^{1/\gamma_i}.$$

Thus, the Equation (9) can now be written as:

$$\mu_{i,n} = nV_i \exp \left[- \left(\frac{n-1}{\omega_i} \right)^{\gamma_i} \right] / L_i, \quad i = 1, 2, \dots, N \tag{10}$$

In order to consider the randomness of service time in the i^{th} circulation facility, the squared coefficient of variation (SCV) of service time should be taken into account. The state-dependent SCV of service time ($C_{i,s,n}^2$) for the i^{th} circulation facility is given by:

$$C_{i,s,n}^2 = \left[\left(\frac{\delta_{i,1}}{v_{i,1}} \right) \exp \left(\left(\frac{n-1}{\omega_i} \right)^{\gamma_i} - \left(\frac{n-1}{\omega'_i} \right)^{\gamma'_i} \right) \right]^2 \tag{11}$$

where,

$$\gamma'_i = \ln \left[\frac{\ln(\delta_{i,a} / \delta_{i,1})}{\ln(\delta_{i,a} / \delta_{i,1})} \right] / \ln \left(\frac{a_i - 1}{b_i - 1} \right),$$

$$\omega'_i = (a_i - 1) \left[\ln \left(\frac{\delta_{i,1}}{\delta_{i,a}} \right) \right]^{1/\gamma'_i}.$$

- $v_{i,1}$ - Mean walking speed when there is only one passenger in the i^{th} circulation facility.
- $\delta_{i,1}$ - Standard deviation of walking speed when there is only one passenger in the i^{th} circulation facility.
- $v_{i,a}$ - Mean walking speed when there are $a_i = 2L_iW_i$ passengers in the i^{th} circulation facility.
- $\delta_{i,a}$ - Standard deviation of walking speed when there are $a_i = 2L_iW_i$ passengers in the i^{th} circulation facility.
- $v_{i,b}$ - Mean walking speed when there are $b_i = 4L_iW_i$ passengers in the i^{th} circulation facility.

$\delta_{i,b}$ - Standard deviation of walking speed when there are $b_i = 4L_iW_i$ passengers in the i^{th} circulation facility.

After fitting the PH distribution, the passenger arrival process can be described by the initial probability vector α_i and the transient generator matrix D_i as:

$$A_i \sim \text{PH}(\alpha_i, D_i) \quad i = 1, 2, \dots, N$$

The state-dependent service process of the i^{th} circulation facility can be described by the initial probability vector $\beta_{i,n}$ and the transient generator matrix $H_{i,n}$ as:

$$B_i(n) \sim \text{PH}(\beta_{i,n}, H_{i,n}) \quad i = 1, 2, \dots, N \quad \text{and} \quad n = 1, 2, \dots, C$$

The above initial probability vectors and transient generator matrix will be used for generating the PH random variates in the PH-based DES model.

6. PH-based DES Model of the Circulation Facilities

First, we introduce the generation of PH random variates that are the key ingredient for PH-based DES model. Then a PH-based DES model of circulation facilities is developed in the *SimEvents*[®] to evaluate the performance measures of the circulation facilities.

6.1. Generation of PH Random Variates

PH distribution is proposed in this paper to simulate the passengers' arrival rate and state-dependent service time of circulation facilities. Neuts (1981) developed a 'Count Procedure' for the efficient generation of PH random variates relies on generating an Erlang-distributed sample with degree f and parameter φ given as:

$$\text{Erl}(f, \varphi) = -\frac{1}{\varphi} \ln \left(\prod_{j=1}^f U_j \right)$$

A pseudo-codes description of generating the PH random variates in this work is as follows:

Pseudo-code 1.

- 1) $x_{ph} := 0, f_j = 0$, for $j = 1, 2, \dots, n$ Draw an α -distributed discrete sample for the initial state.
 - 2) The chain in the state j ,
 - i. $f_j += 1$
 - ii. a $b_j(-\text{diag}(1/d_{jj}, \mathbf{0})\bar{\mathbf{D}} + \mathbf{I})$ - distributed discrete sample is drawn for the next state,
 - iii. in case the next state is an absorbing state then goes to 3 otherwise stay at 2 and repeat
 - for $j=1, 2, \dots, n$;
 - 3) do $x_{ph} += \text{Erl}(f_j, d_{jj})$;
done
 - 4) Return x_{ph} .
-

where, U is the uniformly distributed random number $[0, 1]$. Let b_j represent the row vector with 1 at position j . The 'Count Procedure' of drawing a sample from the Erlang distribution of length f_j is more efficient than drawing samples from the exponential distribution. The Erlang distribution requires a single logarithm operation opposed to the f_j logarithms when drawing individual exponential samples. This procedure instead of drawing exponential samples for each visit to a state j counts the number of visits and then draws one Erlang-distributed sample for each state.

6.2. PH-based DES Model Architecture

A PH-based DES model of the urban rail transit station circulation facilities is built in *SimEvents*[®] in this subsection, as shown in Figure 3a. In contrast to the PH-based analytical queuing model proposed in Hu et al 2015, the PH-based DES model eliminates the need to solve large matrix equations to estimate the performance measures.

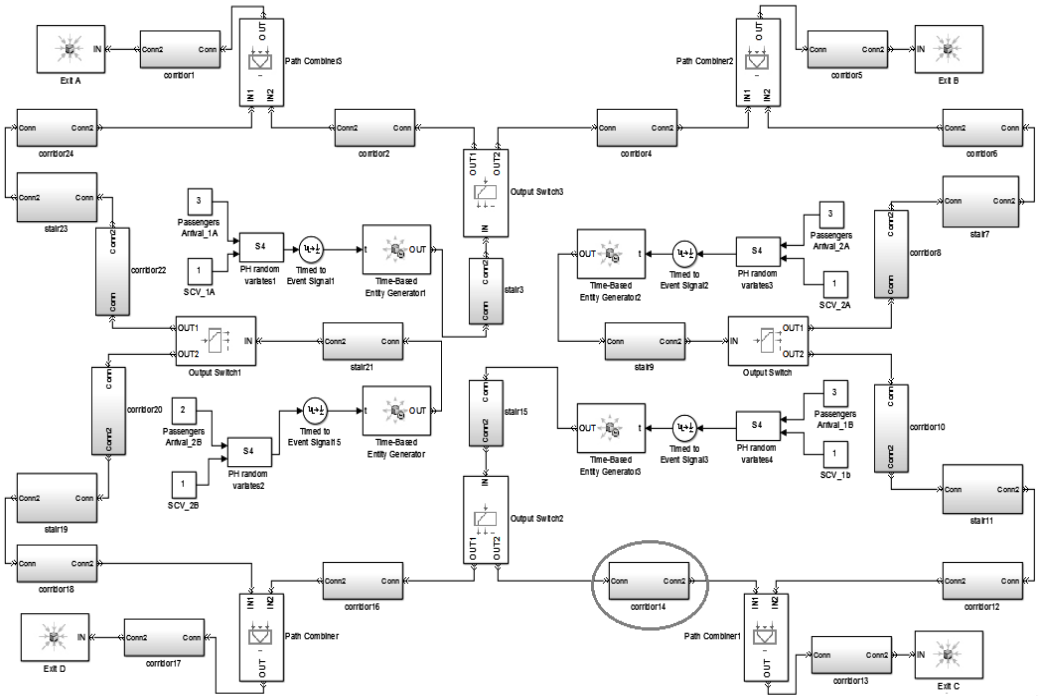

(a) *SimEvents*[®] implementation of urban rail transit station circulation facilities network

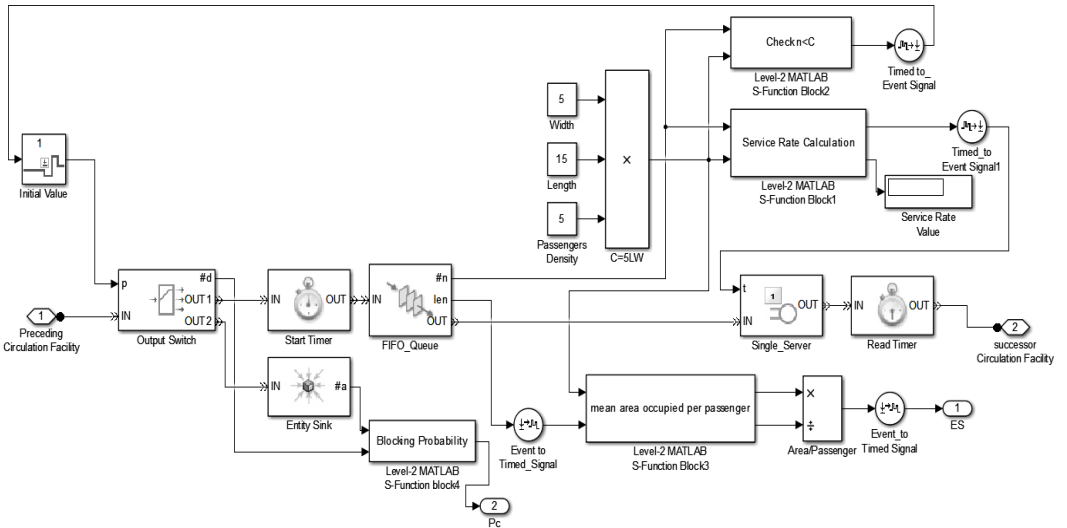

(b) State-dependent service phase of the urban rail transit station circulation facility

Fig. 3. PH-based DES Model Architecture

Each circulation facility in PH-based DES model is described as a PH/PH (n)/C/C queueing system. An overview of the PH-based DES model of each circulation facility is presented in Figure 3b. The key components used in a PH-based DES model are as follows:

- The *Time-Based Entity Generation* block represents the source of passengers
- The *FIFO_Queue* block represents the passenger queueing space
- The *Single-Server* block stores the entities for certain period of time (entities in our case are passengers)
- The *Start and Read Timers* blocks report the time associated with the passengers
- The *Level-2 MATLAB® S-function* blocks compute and update different parameters in the PH-based DES model
- The *Event to Timed Signal* block and *Timed to Event Signal* block convert event-based signals to time-based signals and vice versa
- The *Constant* blocks are used to input different constant parameters values in the DES model while
- The *Display* blocks show the performance measure (output)
- The *SimOut* blocks export the values of performance measures from *SimEvents®* simulation to *MATLAB®* programming environment.

6.3. Passengers Generation Phase

In the PH-based DES model as shown in Figure 3a, the passengers are first generated at the entrance of the stairs on the platforms (No. 3, 9, 15 and 21) (see Figure 1) after alighting the train on Line 1 and Line 2 at the transfer station. The PH random variates are programmed in *Level-2 MATLAB® S-function* blocks (designated as S4) at passenger generation phase using ‘Count Procedure’ as discussed above. The two input parameters for the computation of PH random variates are the initial probability vector and the transient generator matrix that can be obtained by passenger arrival rate λ_a and SCV of arrival interval c_a^2 by using Equation (3), (4) and (5) respectively.

6.4. State-dependent Service Phase

After the generation, passengers will move forward to the circulation facilities. If the number of the passengers in the targeted facility is smaller than its capacity, passengers arriving at the i^{th} circulation facility form a queue and have to wait to be served. To implement this condition, the generated passengers are stored in the *FIFO_Queue* block before being delayed by the *Single_Server* block. After being served, the passengers will be sent to the successor circulation facility. During this process, they reduce the free spaces in the circulation facility and affect the walking speed of other passengers crossing the facility.

If the number of the passengers in the targeted facility has reached its capacity $C_i = 5L_iW_i$, the newly arrived passengers cannot enter the facility. To guarantee the number of passengers that enter the circulation facility do not overcome its overall capacity $C_i = 5L_iW_i$, the *Output Switch* is used to introduce another route for the passengers who cannot enter the circulation facility. When the successor circulation facility is not full, passengers will come out of it from the 1stentity port (OUT1), otherwise, passengers will come out from the 2nd entity port (OUT2).

Four *Level-2 MATLAB® S-function* blocks are used in this phase to calculate the state-dependent service time based on PH random variates, mean areas occupied per passengers ‘ ES_i ’, blocking probabilities $P_{c,i}$, and judging the number of passengers to prevent them from entry when maximum capacity $C_i = 5L_iW_i$ is reached as shown in Figure 4b. The state-dependent service time calculation depends on congestion in the circulation facility area. The capacity $C_i = 5L_iW_i$ and number of passengers (n) from the *FIFO_Queue* block are the input parameters of the *Level-2 MATLAB® S-function* blocks. They are used to compute the state-dependent service rate $\mu_{i,n}$ and SCV of state-dependent service rate $c_{i,s,n}^2$ using Equation (10) and Equation (11) respectively. Then the random number for service time will be generated in the same way used when generating arrival intervals. The service time calculation block dynamically updates the service rates as a function of the number of passengers (n) for each circulation facility. At the

same time, two important performance measures are collected. The mean area occupied per passenger ‘ ES_i ’ is calculated by using area of each circulation facility $A_i = L_i W_i$ divided by mean queue length (len) obtained by the *FIFO_Queue* block. The blocking probability $P_{c,i}$ is calculated by using the number of passengers departed via the 2nd entity port of *Output Switch* divided by the total number of passengers departed via both 1st (OUT 1) and 2nd ports (OUT 2).

Before we develop the *simulation-optimization* approach, it is necessary to verify the accuracy of the proposed PH-DES model. Currently, no PH-based analytical model for the network is available. As it is proved in Hu et al 2015 that the M/G(n)/C/C model (Cruz et al. 2005) is a special case of PH-based queuing model and the PH-based queuing model can be converted into the M/G(n)/C/C model if c_a^2 and c_s^2 are equal to 1. Therefore, the existing M/G(n)/C/C network model is applied as a standard for the comparison.

A simple network constituting three corridors, each with size $8 \times 2.5 \text{ m}^2$ in series, splitting and merging network topologies are analyzed. The passenger arrival rate is $\lambda_a = 3 \text{ ped/s}$ in both approach. To compare on the same benchmark, the c_a^2 and c_s^2 are equal to 1 in the PH-based DES model and the c_s^2 in the M/G(n)/C/C model is also 1. Other parameters are the same in the two methods. The performance measures, including the mean number of passengers E[N], mean waiting time in queue E[W], blocking probabilities P_c and throughput θ are computed by the two methods. The results of PH-based DES model are obtained after 10 repetitions (each simulation last 20,000 units to make sure that the performance measures become stable). The results of the two methods are presented in Table 1. The comparison in Table 1 shows that PH-based DES Model has a smaller average relative error and indicates that PH-based DES model can be used with good accuracy in performance evaluation of urban rail transit stations circulation facilities.

Table 1. Comparison of PH-based DES Model and Analytical Model

	Corridor 1		Corridor 2		Corridor 3		Mean Relative Error (%)
	Analytical M/G(n)/C/C	PH-based DES	Analytical M/G(n)/C/C	PH-based DES	Analytical M/G(n)/C/C	PH-based DES	
Series Topology							
P_c	0.33	0.32	0.00	0.00	0.00	0.00	1.01
θ	2.01	2.00	2.01	2.00	2.01	2.01	1.01
E[N]	96.96	96.04	14.56	16.02	14.56	15.94	6.24
E[W]	48.31	47.95	7.26	8.1	7.26	8.02	6.86
Merging Topology							
P_c	0.33	0.32	0.33	0.32	0.53	0.52	2.72
θ	2.00	1.98	2.00	1.98	2.00	1.99	0.84
E[N]	99.51	98.41	99.51	98.33	99.76	98.59	1.17
E[W]	47.82	47.61	47.82	47.33	50.54	50.11	0.77
Splitting Topology							
P_c	0.33	0.32	0.00	0.00	0.00	0.00	1.01
θ	2.01	2.00	1.04	1.04	1.04	1.04	0.17
E[N]	96.96	95.41	7.75	7.70	7.75	7.70	0.97
E[W]	48.31	47.95	7.53	7.45	7.53	7.45	0.96

7. PH-based Simulation-Optimization approach for the widths design

Based on the PH-based DES model, we develop the PH-based *simulation-optimization* approach for the urban rail transit stations circulation facilities width design. The GA is used as an optimization approach in conjunction with the PH-DES model to determine the optimal widths of circulation facilities. The GA is implemented in the *MATLAB*[®] programming environment. The proposed PH-based *simulation-optimization* approach blends both the PH-based DES and GA to work together concurrently and find the optimal widths of the circulation facilities is presented below and the flow chart is presented in Figure 4.

- A set of N number of widths of circulation facilities $W_i = \{w_1, w_2, \dots, w_N\}$ to be optimized under the LOS ‘B’ and the blocking probability P_c below $p = 0.001$.

- The width set W has a domain set $D = \{d_1, d_2, \dots, d_N\}$.

- The multidimensional search space U (one for each width) is defined by

$$U = \{u = \{s_1, \dots, s_N\} \mid s_i \in d_i\}$$

- According to the TCQSM, the LOS of the circulation facilities is reflected by the mean area occupied per passenger ES_i , which means that the ES_i for the circulation facilities for a given LOS must fall within the range $[LOS_{LB,i}, LOS_{UB,i}]$, where $LOS_{LB,i}$ and $LOS_{UB,i}$ are the lower and upper bounds of the mean area occupied per passenger for the given LOS.

- The performance measures (outputs) $ES_i = \{ES_1, \dots, ES_N\}$ and $P_{c,i} = \{P_{c,1}, \dots, P_{c,N}\}$ are estimated by running the PH-based DES model of urban rail transit station circulation facilities (see Figure 4b).

- The mean area occupied per passenger ES for the circulation facilities is $ES_i = L_i W_i / n_i$, ($i = 1, 2, \dots, N$) from which we can see that mean area occupied per passenger will vary with the width W_i . Therefore, the mean area occupied per passenger for the circulation facilities can be

expressed as a function of W_i , that is,

$$ES(W)_i = L_i W_i / n_i$$

Therefore, the width optimization problem is to find the smallest widths that make sure that the Mean area occupied per passenger ES_i fall within the range $[LOS_{LB,i}, LOS_{UB,i}]$ and the blocking probability is smaller than the required value p , that is:

$$\begin{aligned} & \min W_i \\ & \text{s.t. } LOS_{LB,i} \leq ES(W)_i \leq LOS_{UB,i} \\ & P_{c,i}(W) \leq p \end{aligned}$$

In this research, the *MATLAB*[®] GA toolbox released by The MathWorks[™] is used. The default *MATLAB*[®] GA parameter settings are used, except for a decreased population size of 20 and an adjusted termination criterion if the weighted mean change in the fitness function value over x generations is less than 0.01, the algorithm stops.

The GA parameters and their values are listed below. A description and lists of possible values as well as the algorithm description can be found in The MathWork[™].

Population

- Population Size: 20
- Creation Function: Uniform
- Initial Population: []
- Initial Score: []

Reproduction

- Elite Count: 2
- Crossover Fraction: 0.8

Mutation

- Mutation Probability: 0.01

Termination Criteria

- Function Tolerance: 0.01
- Stall Generation: 10
- Time limit: Inf

It should be noted that the population size, stall generation and the termination criteria are adapted for this study. It is possible that changes of other parameters would lead to better optimization results but in this research we develop an integrated PH-based DES model with GA and assess the comparison of width obtained by using this PH-based simulating-optimization and other existing model such as M/G(n)/C/C and D/D/1/C, therefore further experiments with different parameters are not undertaken in the scope of this research.

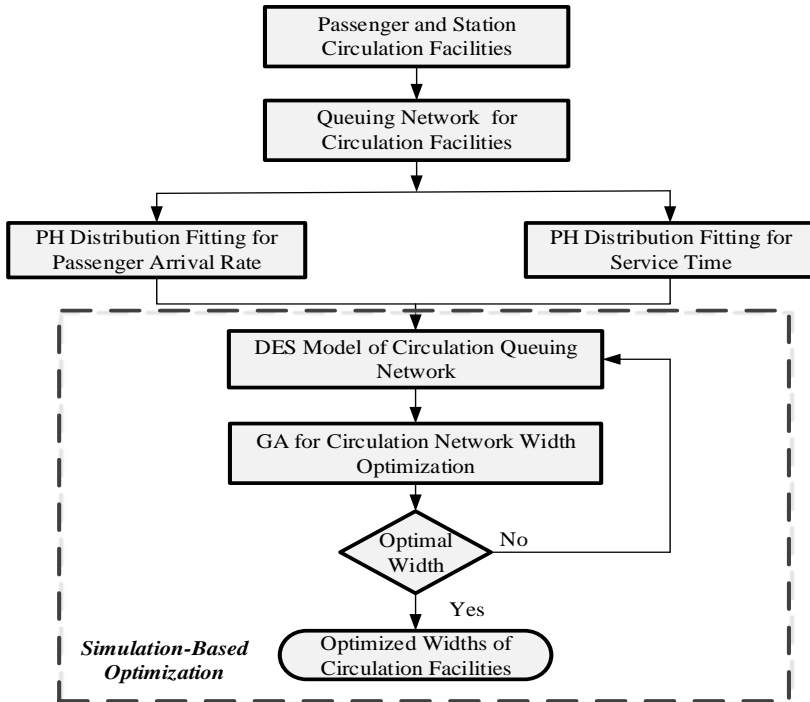

Fig. 4. PH-based *Simulation-Optimization* for the circulation facilities widths design

According to the optimization model, simulation-based optimization approach is proposed. The *MATLAB*[®] programming environment is used to run the PH-based DES model by using ‘*sim*’ command. Since *MATLAB*[®] offers parallel DES and optimization, therefore the performance measure values from the PH-based DES model are transferred from *SimEvents*[®] to *MATLAB*[®] environment by using ‘*yout*’ block. If the constraint function is not satisfied, the GA set new values of parameter to be optimized by using ‘*set_param*’ command and the loop continues until the optimal results are obtained or termination criteria satisfy.

The *simulation-based optimization* works as follow: At first, the interval containing the upper and lower bounds of circulation facilities width $U = [W_{UB,i}, W_{LB,i}]$ is defined which is supposed to contain the optimal width $W_{opt,i}$ of the circulation facilities. The PH-based DES model runs initiate with an arbitrary value from the defined interval to simulate the performance of the circulation facilities

and obtain the performance measure (ES_i and $P_{c,i}$) when simulation system reaches the steady state condition (when the performance measures become stable). Then the Genetic Algorithm (GA) that is programmed in *MATLAB*[®] adjusts the widths W_i according to the value of ES_i and $P_{c,i}$ until the optimal widths $W_{opt,i}$ are found.

To improve the efficiency of the optimization model, a function tolerance η is defined. If the relative change in the objective is less than or equal to the η then the corresponding W_i can be approximately considered as the optimal width $W_{opt,i}$. If the difference is larger than η , the GA will replace W_i from the defined interval $[W_{UB,i}, W_{LB,i}]$ and set the new width value W_i in the PH-based DES model for next iteration to obtain the ES_i and $P_{c,i}$ by the same means. The iterations continue until the relative change in the best fitness

function value is less than or equal to η and the corresponding width W_i is the optimal width $W_{opt,i}$. The minimum allowable width under the TCQSM is 1 meter. But instead of using 1meter as lower bound of width, we set the upper and lower bound calculated. The width design under the LOS ‘B’ will fall in this range and less likely to trap in the local optimum. It should be noted that the search space obtained by using the min and max values of ES neglected the randomness and state-dependent. The search space is used to find the optimal result is obtained from TCQSM. Moreover, after reviewing several literatures, one of the main reasons to use GA is that it searches dozens or hundreds of parts of the search space simultaneously which means that it is less likely to become stuck in "local minima" as the others traditional optimization approaches quite often do. The more details regarding the upper and lower bounds of width with an example to make it clearer is presented. The Exhibit 7-3 (Pedestrian Level of Service in walkways) of TCQSM presents the upper and lower bound values of flow per unit width (ped/m/min) under the different LOS. We use these values as our benchmark to define the upper and lower limit of width. An example is presented below.

Let us consider we design under LOS ‘B’ for peak-hour factor of 0.3 and we have an hourly volume given as 5000 ped/h. The upper and lower limit of flow per unit width under LOS ‘B’ is 33 and 23, respectively from Exhibit 7-3. According to TCQSM, the width of the walkway can be obtained as:

Upper bound of width

$$W_{UB} = \frac{5000}{(0.3)(60)(23)} = 12m$$

$$W_{LB} = \frac{5000}{(0.3)(60)(33)} = 8.4m$$

$[W_{UB} + 2, W_{LB}] = [14, 8.4]$ is used as the upper and lower limit under this condition. The upper bound is increased by an increment of 2 as it is expected to have a design width higher than upper bound due to increase in SCV of arrival internal. It should be noted that these upper and lower bound values are estimated by using TCQSM width design procedure

that neglects randomness and state-dependence. We use these values only to define our search space and initiate our PH-based DES model run.

8. Computational Experiments

In the following section, we will use the proposed PH-based *simulation- optimization* approach to optimally design widths of circulation facilities in the urban rail transit stations. We will design the width for the circulation facilities in Figure 1. The required input parameters for the width design such as passenger arrival rate, SCV of arrival interval, three representative points for walking speed in corridors and stairs and the lengths of circulation facilities are predetermined. The passenger arrival rates λ_i ($i = 3, 9, 15, 21$) values are 2ped/s and 3ped/s according to its actual range in the urban rail transit station. It can also be calculated by using Equation (3). Similarly, the SCV of arrival interval $c_{i,a}^2$ ($i = 3, 9, 15, 21$) values are 100, 300 and 500 according to its actual range in the urban rail transit stations. The SCV of arrival interval can also be determined by using Equation (4) and (5). The three representative points for walking speed in the corridor circulation facilities are $(v_{i,l} = 1.50, \delta_{i,l} = 0.50)$, $(v_{i,a} = 0.64, \delta_{i,a} = 0.21)$ and $(v_{i,b} = 0.25, \delta_{i,b} = 0.08)$ respectively (Hu et al. 2015), while, the three representative point of walking speed in the stairs facilities are $(v_{i,l} = 0.75, \delta_{i,l} = 0.25)$, $(v_{i,a} = 0.32, \delta_{i,a} = 0.11)$ and $(v_{i,b} = 0.12, \delta_{i,b} = 0.04)$ respectively. The state-dependent SCV ($c_{i,s,n}^2$) of service time of the i^{th} circulation facility can be calculated by using Equation.(11). The lengths of corridor facilities are 10m while the lengths of stairs facilities are 15 m. The design widths of all circulation facilities are obtained under the LOS ‘B’ i.e., $ES_i \geq 1.4$ m²/ped and $ES_i \geq 2.3$ m²/ped for stairs and corridors, respectively. The blocking probability $P_{c,i}$ should be below 0.001.

The widths designed by the proposed method are compared with the widths obtained by the existing M/G(n)/C/C (Cruz et al., 2005) and D/D/1/C (Kittelson et al., 2003) analytical approaches. The

design procedure in TCQSM is similar to uses a fixed arrival rate and a fixed service time, which is essentially a D/D/1/C analytical queuing model (Jiang et al 2015). The SCV is equal to 1/30 (0.03) as it neglect randomness and state-dependence. We use the D/D/1/C queuing model to represent the width design procedure of TCQSM for the circulation facilities.

The widths designed by the three methods, the proposed PH-based *simulation-optimization* approach, the M/G(n)/C/C analytical model, and the D/D/1/C analytical model, are presented in Figure 5 and 6. The figures reveal some important and interesting findings:

- 1) The design widths obtained by the PH-based *simulation-optimization* are greater than that of the M/G (n)/C/C and the D/D/1/C analytical model for all the arrival rates and SCV of arrival intervals. Figure 5 illustrates the design widths of the three approaches under the same arrival rate $\lambda = 2$ ped/s and different SCV of arrival interval (100, 300 and 500). Compared to the width designed by the D/D/1/C model, the average increase in the width of the proposed method is 0.43 m when the SCV of arrival intervals is 100, 0.83 m when the SCV of arrival intervals is 300, and 1.21 m when the SCV of arrival intervals is 500. Compared to the width designed by the M/G (n)/C/C model, the average increase in the width for the *simulation-optimization* is 0.29 m when the SCV of arrival intervals is 100, 0.69 m when the SCV of arrival intervals is 300, and 1.08 m when the SCV of arrival intervals is 500. Figure 6 shows similar trend for arrival rate $\lambda = 3$ ped/s. We can see the circulation facilities designed by the PH-based *simulation-optimization* approach has larger widths because it describes the circulation system more elaborate and considers both the LOS and the blocking probability.
- 2) The widths of the M/G (n)/C/C and D/D/1/C stay the same when the SCV of arrival interval changes from 100 to 500. On the contrary, the widths for the PH-based *simulation-optimization* increase with the increase in the SCV of arrival interval. This is because in the D/D/1/C, the randomness and state-dependence are completely ignored while in M/G(n)/C/C the passenger flow is assumed as a free flow where the SCV of arrival interval equals 1. Therefore, the design

width of the two methods will not increase with the SCV of arrival interval. This result shows that the design methods based on the M/G (n)/C/C and D/D/1/C models are not applicable in practical systems where the SCV of arrival interval is far more than 1. On the contrary, the width of the proposed PH-based *simulation-optimization* approach is sensitive to the SCV of arrival interval.

- 3) For all the three design approaches, the widths of circulation facilities increase with the increase in passenger arrival rate when the SCV of arrival interval remains same. It is expected because of the fact that these design approaches are sensitive to the arrival rate. When the arrival rate increase from 2 to 3 ped/s, the average increase of the PH-based *simulation-optimization*, M/G (n)/C/C and D/D/1/C are 1.51 m(47%), 0.82 m(31%) and 0.76 m(31%) respectively. The PH-based *simulation-optimization* approach has a larger growth than the other two methods.
- 4) For all arrival rates and SCV of arrival intervals, the design widths of stairs facilities are greater than corridors facilities. It is quite obvious because of the fact that passengers' walking speed on stairs is slower than that in the corridors. Thus more passengers are stranded in the stairs facilities, which will cause blocking and reduction in the mean area occupied per passenger 'ES'. Therefore, stairs require more width to keep the mean area occupied per passenger in the LOS 'B' range and blocking probability below 0.001. In addition, the widths of corridors No. 1,5,13 and 17 are greater than the other corridors because of merging topologies that require more widths to keep the 'ES' above 2.3m²/ped and blocking probability below 0.001.
- 5) It is observed that the average difference in the design widths of M/G (n)/C/C and D/D/1/C is 0.14 m, which is much smaller than the difference between the width of the M/G (n)/C/C or D/D/1/C model with the width of the PH-based *simulation-optimization*. This also illustrates that proposed approach can reveal the extra requirement on width which is ignored by the existing methods.

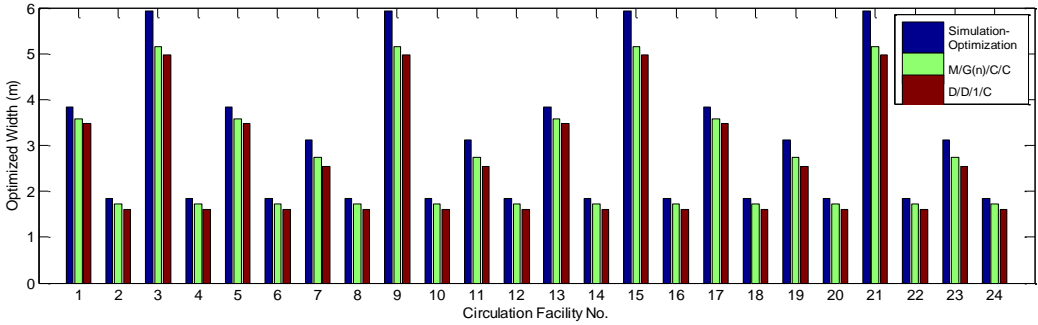

(a) Comparison of design widths for passenger arrival rate $\lambda = 2$ ped/s and SCV=100

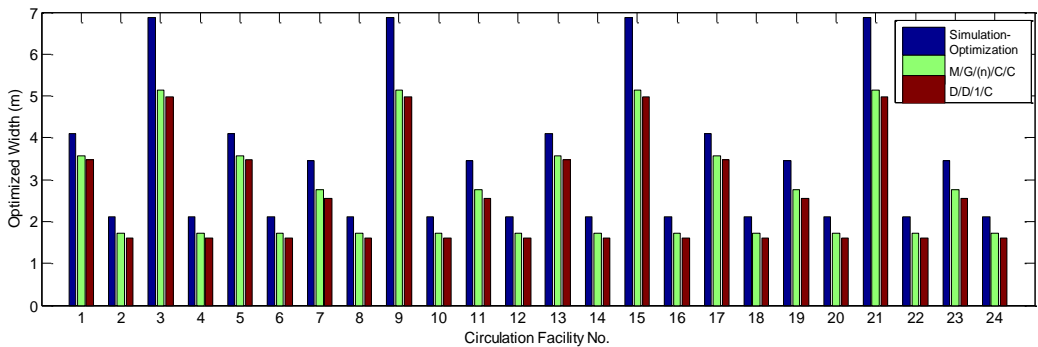

(b) Comparison of design widths for passenger arrival rate $\lambda = 2$ ped/s and SCV=300

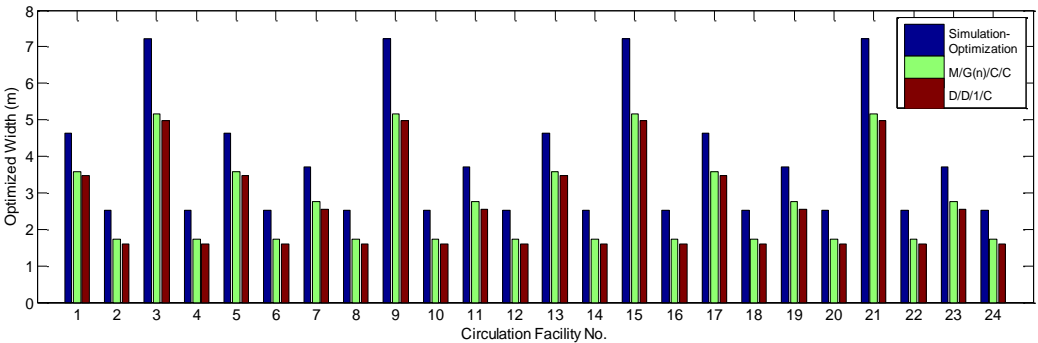

(c) Comparison of design widths for passenger arrival rate $\lambda = 2$ ped/s and SCV=500

Fig. 5. Design widths comparison for passenger arrival rate $\lambda = 2$ ped/s

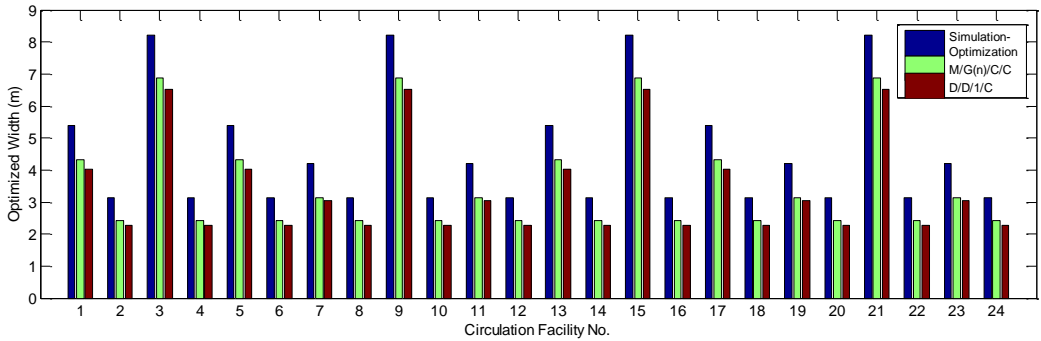

(a) Comparison of design widths for passenger arrival rate $\lambda = 3\text{ped/s}$ and $\text{SCV}=100$

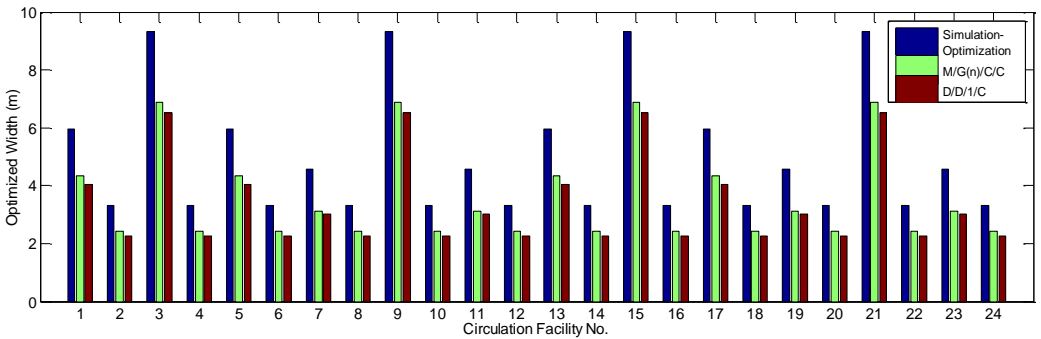

(b) Comparison of design widths for passenger arrival rate $\lambda = 3\text{ ped/s}$ and $\text{SCV}=300$

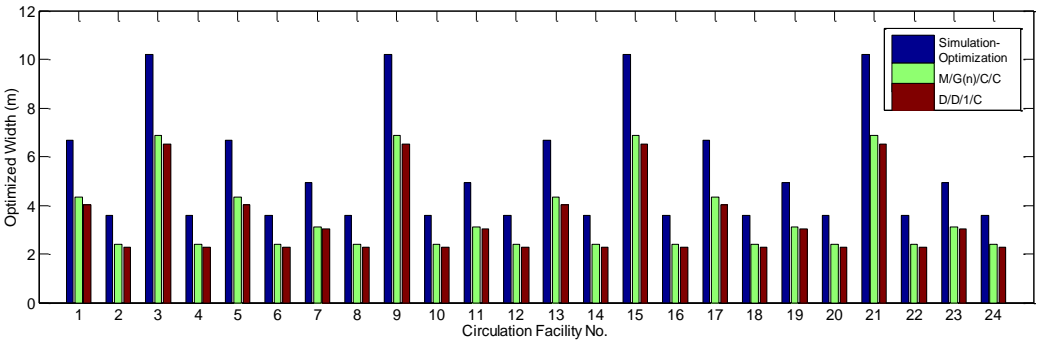

(c) Comparison of design widths for passenger arrival rate $\lambda = 3\text{ ped/s}$ and $\text{SCV}=500$

Fig. 6. Design widths comparison for passenger arrival Rate $\lambda = 3\text{ ped/s}$

9. Conclusions and Future work

This paper proposes a PH-based *simulation-optimization* approach by integrating a PH-based DES model and GA for the widths design of circulation facilities in urban rail transit station. The

proposed approach overcomes the shortcomings in the existing design approaches by fully consider the randomness and state dependence in the PH-based DES model and consider the requirement on both LOS and blocking probability in the optimization. A

comparison is made between the M/G (n)/C/C model and the proposed PH-based DES model to verify the accuracy of the latter one. The results show that the PH-based DES model has achieved clear consistency with the analytical approach. In addition, the experiments on width design are carried out by comparing the PH-based *simulation-optimization* approach with the existing design approaches.

The numerical experiments reveal some interesting findings: (1) The circulation facilities designed by the PH-based *simulation-optimization* approach has larger widths compared with that designed by the existing methods; (2) The width of the proposed method increase with the SCV of arrival interval, while the widths of the design methods based on the M/G (n)/C/C and D/D/1/C models stays the same where the SCV of arrival interval increases; (3) The width of the proposed method increase faster than the other two methods when the arrival rate increases; (4) Under the same passenger flow conditions, stairs require more width to meet the requirement on LOS and blocking probability.

This new proposed PH-based *simulation-optimization* approach, integrating PH-based DES and optimization can help the planners and designers of urban rail transit station to make decisions regarding urban rail transit station design. This approach can also be applied to design circulation facilities in other public buildings such as shopping malls and hospitals etc., if the pedestrian peak hour flow, circulation facilities lengths, the desired LOS and peak hour factors are known. The PH-based *simulation-optimization* is particularly useful in situations where the analytical expressions are too complex to obtain. At the same time, this approach can serve as an important tool for verifying the PH-based analytical model developed in Hu et al. (2015).

This paper only considers rectangular circulation facilities for evaluation and design purpose. Other complicated circulation facilities that are not rectangular can be divided into several rectangular facilities and then be evaluated in the same way. The principle procedure of circulation facilities transformation into a single server queuing system remains the same. In addition, we only consider the unidirectional passenger flow in this paper. But the model can also deal with bidirectional or multidirectional passengers flow by only adjusting

the speed parameters. Moreover, the queuing system is considered to be a loss queue without feedback. However, feedback always exists in circulation facilities when congestion happens. A PH-based DES model for a feedback queuing system will be addressed in our future research.

Acknowledgment

We would like to express our sincere acknowledgment to National Natural Science Foundation of China (Serial No. 51578465 and 71402149), Basic Research Project of Sichuan Province, the Chinese government for funding of PhD doctoral program at Southwest Jiaotong University and the colleagues of National United Engineering Laboratory of Integrated and Intelligent Transportation at Southwest Jiaotong University, Chengdu for their support and valuable advice.

References

- [1] ALFA, A. S., and ZHAO, Y. Q., 2000. Overload analysis of the PH/PH/1/K queue and the queue of M/G/1/K type with very large K. *Asian Pacific Journal of Operational Research*, 17, 122-136.
- [2] BANKS, J. (2010). *Discrete-event System Simulation*, Prentice Hall.
- [3] CASSANDRAS, C. G., & LAFORTUNE, S., 2009. *Introduction to Discrete Event Systems*: Springer US.
- [4] CHEAH, J., and SMITH, J. M., 1994. Generalized M/G/C/C state dependent queueing models and pedestrian traffic flows. *Queueing System*, 15(1-4), 365-386.
- [5] CHEN, S. K., and S. Liu, XIAOM, X., 2012. M/G/C/C-based Model of Passenger Evacuation Capacity of Stairs and Corridors in Urban Rail Transit Station. *Journal of China Railway Society*, 34, 7-12.
- [6] CRUZ, F. R. B., MACGREGOR SMITH, J., AND MEDEIROS, R. O., 2005. An M/G/C/C state-dependent network simulation model. *Computers & Operations Research*, 32(4), 919-941.
- [7] CRUZ, F. R. B., SMITH, J. M., AND QUEIROZ, D. C., 2005. Service and capacity allocation in M/G/C/C state-dependent queueing networks. *Computers & Operations Research*, 32(6), 1545-1563.

- [8] FIGUEIRA G, ALMADA-LOBO B., 2014. Hybrid simulation–optimization methods: A taxonomy and discussion[J]. *Simulation Modelling Practice and Theory*, 46, 118-134.
- [9] FU, M. C., 2002. Feature Article: Optimization for simulation: Theory vs. Practice. *INFORMS Journal on Computing*, 14(3), 192-215.
- [10] HAGENDORF, O., PAWLETTA, T. and LAREK, R., 2013. An approach for simulation-based parameter and structure optimization of MATLAB/Simulink models using evolutionary algorithms. *SIMULATION*.
- [11] HASSANNAYEBI E, SAJEDINEJAD A, MARDANI S., 2014. Urban rail transit planning using a two-stage simulation-based optimization approach. *Simulation Modelling Practice and Theory*, 49, 151-166.
- [12] HU, L., JIANG, Y., ZHU, J., and CHEN, Y., 2015. A PH/PH state-dependent queuing model for metro station corridor width design. *European Journal of Operational Research*, 240(1), 109-126.
- [13] HUBSCHER-YOUNGER, T., MOSTERMAN, P. J., DELAND, S., ORQUEDA, O., and EASTMAN, D., 2012. Integrating discrete-event and time-based models with optimization for resource allocation. *Proc., Simulation Conference (WSC), Proceedings of the 2012 Winter*, 1-15.
- [14] JACYNA, M., WASIAK, M., LEWCZUK, K., KŁODAWSKI, M., 2015. Simulation model of transport system of poland as a tool for developing sustainable transport. *The Archives of Transport*, 31(3), 23-35.
- [15] JIANG, Y., and LIN, X., 2013. Simulation and Optimization of the Ticket Vending Machine Configuration in Metro Stations Based on Anylogic Software. *Fourth International Conference on Transportation Engineering*, 754-760.
- [16] JIANG, Y., HU, L., and LU, G., 2010. Determined method of subway footway width based on queuing theory. *Journal of Traffic and Transportation Engineering*, 10, 61-67.
- [17] JIANG, Y., HU, L., ZHU, J., and CHEN, Y., 2013. PH fitting of the arrival interval distribution of the passenger flow on urban rail transit stations. *Applied Mathematics and Computation*, 225, 158-170.
- [18] JIANG, Y., ZHU, J., HU, L., LIN, X., and KHATTAK, A., 2016. A G/G(n)/C/C state-dependent simulation model for metro station corridor width design. *Journal of Advanced Transportation*, 50, 273–295.
- [19] KAAKAI F, HAYAT S, EL MOUDNI A., 2007. A hybrid Petri nets-based simulation model for evaluating the design of railway transit stations. *Simulation Modelling Practice and Theory*, 15(8), 935-969.
- [20] KHALID, R., M. NAWAWI, M. K., KAWSAR, L. A., GHANI, N. A., KAMIL, A. A., and MUSTAFA, A., 2013. A Discrete Event Simulation Model for Evaluating the Performances of an M/G/C/C State Dependent Queuing System. *PLoS ONE*, 8(4), e58402.
- [21] KITTELSON, Associates, Administration, U. S. F. T., Program, T. C. R., Corporation, T. D., and Board, N. R. C. T. R., 2003. *Transit Capacity and Quality of Service Manual*, Transportation Research Board of the National Academies.
- [22] KRISHNAMOORTHY, A., BABU, S., and NARAYANAN, V. C., 2008. MAP/(PH/PH)/c Queue with Self-Generation of Priorities and Non-Preemptive Service. *Stochastic Analysis and Applications*, 26(6), 1250-1266.
- [23] LEWCZUK, K., 2015. The concept of genetic programming in organizing internal transport processes. *Archives of Transport*, 34(2), 61-74.
- [24] LÖVÅS, G. G., 1994. Modeling and simulation of pedestrian traffic flow. *Transportation Research Part B: Methodological*, 28(6), 429-443.
- [25] SMITH, J. M. G., 1991. State-dependent queueing models in emergency evacuation networks. *Transportation Research Part B: Methodological*, 25(6), 373-389.
- [26] MESSAC, A., 2015. *Optimization in Practice with MATLAB*, Cambridge University Press.
- [27] MITCHELL, D. H., and MACGREGOR SMITH, J., 2001. Topological network design of pedestrian networks. *Transportation Research Part B: Methodological*, 35(2), 107-135.
- [28] MIYAZAWA, M., SAKUMA, Y., & YAMAGUCHI, S., 2007. Asymptotic Behaviors of the Loss Probability for a Finite Buffer Queue with QBD Structure. *Stochastic Models*, 23(1), 79-95.

- [29] NEUTS, M. F., 1981. *Matrix-geometric Solutions in Stochastic Models: An Algorithmic Approach*, Dover Publications.
- [30] SADRE, R., 2007. *Decomposition-based analysis of queueing networks*. University of Twente, Twente.
- [31] SADRE, R., and HAVERKORT, B., 2011. Decomposition-Based Queueing Network Analysis with FiFiQueues. *Queueing Networks*, R. J. Boucherie, and N. M. van Dijk, eds., Springer US, 643-699.
- [32] SWISHER, J. R., HYDEN, P. D., JACOBSON, S. H., and SCHRUBEN, L. W., 2000. Simulation optimization: a survey of simulation optimization techniques and procedures. *Proceedings of the 32nd conference on Winter simulation*, Society for Computer Simulation International, Orlando, Florida, 119-128.
- [33] TEKNOMO, K., 2006 Application of microscopic pedestrian simulation model. *Transportation Research Part F: Traffic Psychology and Behaviour*, 9(1), 15-27.
- [34] TREGENZA, P., 1976. *The design of interior circulation*, Van Nostrand Reinhold.
- [35] XU, X., LIU, J., LI, H., AND HU, J., 2014. Analysis of subway station capacity with the use of queueing theory. *Transportation Research Part C: Emerging Technologies*, 38, 28-43.
- [36] YUHASKI, S. J., and SMITH, J. M., 1989. Modeling circulation systems in buildings using state dependent queueing models. *Queueing Systems*, 4(4), 319-338.